

AUTOMATIC THREAD EMULSIFIER MOD. 6/A

The unit is made of AISI 304 stainless steel. It is applied to the finishing machine on the lines for processing pig and sheep casings. The machine automatically carries out the phases of feeding, emulsifying and expelling the product making the product suitable to be conveyed with pumps or pneumatic canons.

The machine is supplied complete with:

- Low-voltage electrical control panel, to CEI standards, with motor protection

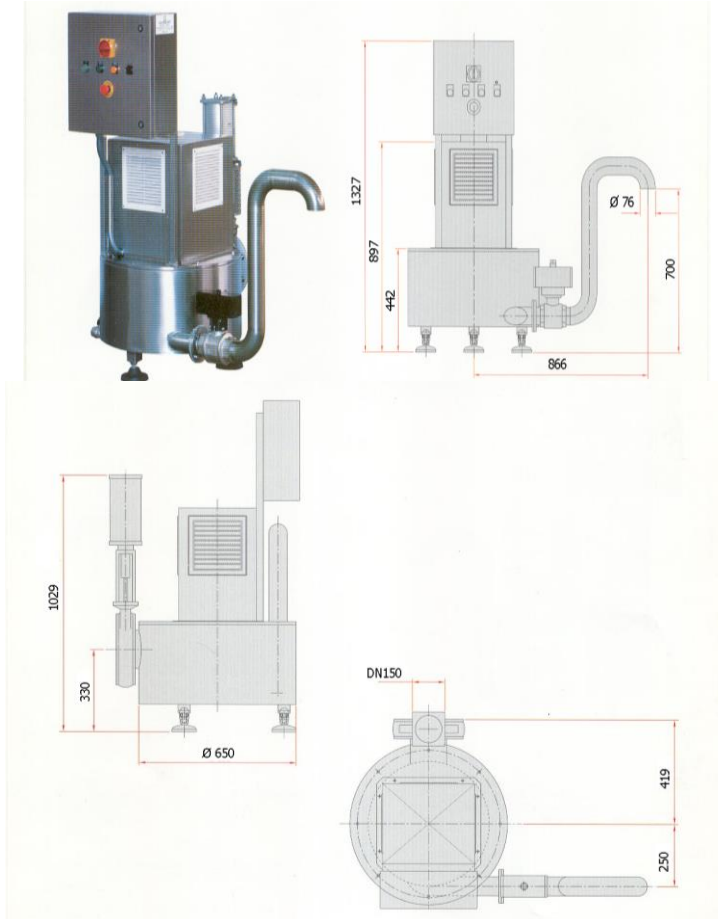

Technical features	
400V, 50Hz, 3 Phase	Air consumption/h (6 bar)
Kw 7.5	500l/h -approx
Dimensions	Weight
650x750x1327 H.mm	130Kg